

On interactive possibility distributions*

Robert Fullér

Department of OR, Eötvös Loránd University,
Pázmány Péter sétány, 1/C, H-1147 Budapest, Hungary

Péter Majlender

TUCS/IAMSR, Åbo Akademi University,
Lemminkäinenkatu 14B, FIN-20520 Åbo, Finland

Abstract

In 2001 Carlsson and Fullér [1] introduced the possibilistic mean value, variance and covariance of fuzzy numbers. In 2003 Fullér and Majlender [4] introduced the notations of crisp weighted possibilistic mean value, variance and covariance of fuzzy numbers, which are consistent with the extension principle. In 2003 Carlsson, Fullér and Majlender [2] proved the possibilistic Cauchy-Schwartz inequality. Drawing heavily on [1, 2, 3, 4, 5] we will summarize some normative properties of possibility distributions.

1 Probability

In probability theory, the dependency between two random variables can be characterized through their joint probability density function. Namely, if X and Y are two random variables with probability density functions $f_X(x)$ and $f_Y(y)$, respectively, then the density function, $f_{X,Y}(x, y)$, of their joint random variable (X, Y) , should satisfy the following properties

$$\int_{\mathbb{R}} f_{X,Y}(x, t)dt = f_X(x), \int_{\mathbb{R}} f_{X,Y}(t, y)dt = f_Y(y),$$

for all $x, y \in \mathbb{R}$. Furthermore, $f_X(x)$ and $f_Y(y)$ are called the marginal probability density functions of random variable (X, Y) . X and Y are said to be independent if

$$f_{X,Y}(x, y) = f_X(x)f_Y(y),$$

holds for all x, y . The expected value of random variable X is defined as

$$E(X) = \int_{\mathbb{R}} xf_X(x)dx,$$

*appeared in: V.A. Niskanen and J. Kortelainen eds., *On the Edge of Fuzziness, Studies in Honor of Jorma K. Mattila on His Sixtieth Birthday*, Acta universitatis Lappeenrantaensis, No. 179, [ISBN 951-764-883-9], 2004 61-69.

and if g is a function of X then the expected value of $g(X)$ can be computed as

$$E(g(X)) = \int_{\mathbb{R}} g(x) f_X(x) dx.$$

Furthermore, if h is a function of X and Y then the expected value of $h(X, Y)$ can be computed as

$$E(h(X, Y)) = \int_{\mathbb{R}^2} h(x, y) f_{X,Y}(x, y) dx dy.$$

Especially,

$$E(X + Y) = E(X) + E(Y),$$

that is, the expected value of X and Y can be determined according to their individual density functions (that are the marginal probability functions of random variable (X, Y)).

Remark 1.1. *The key issue here is that the joint probability distribution vanishes (even if X and Y are not independent), because of the principle of 'falling integrals'.*

Let $a, b \in \mathbb{R} \cup \{-\infty, \infty\}$ with $a \leq b$, then the probability that X takes its value from $[a, b]$ is computed by

$$P(X \in [a, b]) = \int_a^b f_X(x) dx.$$

The covariance between two random variables X and Y is defined as

$$\text{Cov}(X, Y) = E((X - E(X))(Y - E(Y))) = E(XY) - E(X)E(Y),$$

and if X and Y are independent then $\text{Cov}(X, Y) = 0$, since $E(XY) = E(X)E(Y)$.

The variance of random variable X is defined as the covariance between X and itself, that is

$$\text{Var}(X) = E(X^2) - (E(X))^2 = \int_{\mathbb{R}} x^2 f_X(x) dx - \left(\int_{\mathbb{R}} x f_X(x) dx \right)^2.$$

For any random variables X and Y and real numbers $\lambda, \mu \in \mathbb{R}$ the following relationship holds

$$\text{Var}(\lambda X + \mu Y) = \lambda^2 \text{Var}(X) + \mu^2 \text{Var}(Y) + 2\lambda\mu \text{Cov}(X, Y).$$

The correlation coefficient between X and Y is defined by

$$\rho(X, Y) = \frac{\text{Cov}(X, Y)}{\sqrt{\text{Var}(X)\text{Var}(Y)}},$$

and it is clear that $-1 \leq \rho(X, Y) \leq 1$.

2 Interactive possibility distributions

A fuzzy set A in \mathbb{R} is said to be a fuzzy number if it is normal, fuzzy convex and has an upper semi-continuous membership function of bounded support. The family of all fuzzy numbers will be denoted by \mathcal{F} . A γ -level set of a fuzzy set A in \mathbb{R}^m is defined by $[A]^\gamma = \{x \in \mathbb{R}^m : A(x) \geq \gamma\}$ if $\gamma > 0$ and $[A]^\gamma = \text{cl}\{x \in \mathbb{R}^m : A(x) > \gamma\}$ (the closure of the support of A)

if $\gamma = 0$. If $A \in \mathcal{F}$ is a fuzzy number then $[A]^\gamma$ is a convex and compact subset of \mathbb{R} for all $\gamma \in [0, 1]$.

Fuzzy numbers can be considered as possibility distributions [6, 7]. Let $a, b \in \mathbb{R} \cup \{-\infty, \infty\}$ with $a \leq b$, then the possibility that $A \in \mathcal{F}$ takes its value from $[a, b]$ is defined by [7]

$$\text{Pos}(A \in [a, b]) = \max_{x \in [a, b]} A(x).$$

A fuzzy set B in \mathbb{R}^m is said to be a joint possibility distribution of fuzzy numbers $A_i \in \mathcal{F}$, $i = 1, \dots, m$, if it satisfies the relationship

$$\max_{x_j \in \mathbb{R}, j \neq i} B(x_1, \dots, x_m) = A_i(x_i),$$

for all $x_i \in \mathbb{R}$, $i = 1, \dots, m$. Furthermore, A_i is called the i -th marginal possibility distribution of B , and the projection of B on the i -th axis is A_i for $i = 1, \dots, m$.

Let B denote a joint possibility distribution of $A_1, A_2 \in \mathcal{F}$. Then B should satisfy the relationships

$$\max_y B(x_1, y) = A_1(x_1),$$

$$\max_y B(y, x_2) = A_2(x_2),$$

for all $x_1, x_2 \in \mathbb{R}$.

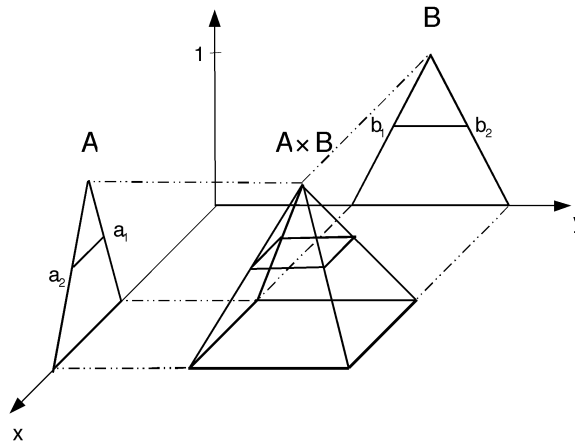

Figure 1: Non-interactive possibility distributions.

If $A_i \in \mathcal{F}$, $i = 1, \dots, m$, and B is their joint possibility distribution then the relationships

$$B(x_1, \dots, x_m) \leq \min\{A_1(x_1), \dots, A_m(x_m)\},$$

and

$$[B]^\gamma \subseteq [A_1]^\gamma \times \dots \times [A_m]^\gamma,$$

hold for all $x_1, \dots, x_m \in \mathbb{R}$ and $\gamma \in [0, 1]$.

In the following the biggest (in the sense of subsethood of fuzzy sets) joint possibility distribution will play a special role among joint possibility distributions: it defines the concept of non-interactivity of fuzzy numbers (see Fig. 1).

Definition 2.1. Fuzzy numbers $A_i \in \mathcal{F}$, $i = 1, \dots, m$, are said to be non-interactive if their joint possibility distribution, B , is given by

$$B(x_1, \dots, x_m) = \min\{A_1(x_1), \dots, A_m(x_m)\},$$

or, equivalently,

$$[B]^\gamma = [A_1]^\gamma \times \dots \times [A_m]^\gamma,$$

for all $x_1, \dots, x_m \in \mathbb{R}$ and $\gamma \in [0, 1]$.

Remark 2.1. Marginal probability distributions are determined from the joint one by the principle of 'falling integrals' and marginal possibility distributions are determined from the joint possibility distribution by the principle of 'falling shadows'.

Let $A \in \mathcal{F}$ be fuzzy number with $[A]^\gamma = [a_1(\gamma), a_2(\gamma)]$, $\gamma \in [0, 1]$. A function $f: [0, 1] \rightarrow \mathbb{R}$ is said to be a weighting function [4] if f is non-negative, monotone increasing and satisfies the following normalization condition

$$\int_0^1 f(\gamma) d\gamma = 1.$$

3 Possibilistic expected value, variance, covariance

Let B be a joint possibility distribution in \mathbb{R}^n , let $\gamma \in [0, 1]$ and let $g: \mathbb{R}^n \rightarrow \mathbb{R}$ be an integrable function. It is well-known from analysis that the average value of function g on $[B]^\gamma$ can be computed by

$$\begin{aligned} \mathcal{C}_{[B]^\gamma}(g) &= \frac{1}{\int_{[B]^\gamma} dx} \int_{[B]^\gamma} g(x) dx \\ &= \frac{1}{\int_{[B]^\gamma} dx_1 \dots dx_n} \int_{[B]^\gamma} g(x_1, \dots, x_n) dx_1 \dots dx_n. \end{aligned}$$

We will call \mathcal{C} as the central value operator.

If $g: \mathbb{R} \rightarrow \mathbb{R}$ is an integrable function and $A \in \mathcal{F}$ then the average value of function g on $[A]^\gamma$ is defined by

$$\mathcal{C}_{[A]^\gamma}(g) = \frac{1}{\int_{[A]^\gamma} dx} \int_{[A]^\gamma} g(x) dx.$$

Especially, if $g(x) = x$, for all $x \in \mathbb{R}$ is the identity function ($g = \text{id}$) and $A \in \mathcal{F}$ is a fuzzy number with $[A]^\gamma = [a_1(\gamma), a_2(\gamma)]$ then the average value of the identity function on $[A]^\gamma$ is computed by

$$\mathcal{C}_{[A]^\gamma}(\text{id}) = \frac{1}{\int_{[A]^\gamma} dx} \int_{[A]^\gamma} x dx = \frac{1}{a_2(\gamma) - a_1(\gamma)} \int_{a_1(\gamma)}^{a_2(\gamma)} x dx = \frac{a_1(\gamma) + a_2(\gamma)}{2},$$

which remains valid in the limit case $a_2(\gamma) - a_1(\gamma) = 0$ for some γ . Because $\mathcal{C}_{[A]^\gamma}(\text{id})$ is nothing else, but the center of $[A]^\gamma$ we will use the shorter notation $C([A]^\gamma)$ for $\mathcal{C}_{[A]^\gamma}(\text{id})$.

It is clear that $\mathcal{C}_{[B]^\gamma}$ is linear for any fixed joint possibility distribution B and for any $\gamma \in [0, 1]$.

We can also use the principle of central values to introduce the notion of expected value of functions on fuzzy sets. Let $g: \mathbb{R} \rightarrow \mathbb{R}$ be an integrable function and let $A \in \mathcal{F}$. Let us consider again the average value of function g on $[A]^\gamma$

$$\mathcal{C}_{[A]^\gamma}(g) = \frac{1}{\int_{[A]^\gamma} dx} \int_{[A]^\gamma} g(x) dx.$$

Definition 3.1. [5] *The expected value of function g on A with respect to a weighting function f is defined by*

$$E_f(g; A) = \int_0^1 \mathcal{C}_{[A]^\gamma}(g) f(\gamma) d\gamma = \int_0^1 \frac{1}{\int_{[A]^\gamma} dx} \int_{[A]^\gamma} g(x) dx f(\gamma) d\gamma.$$

Especially, if g is the identity function then we get

$$E_f(\text{id}; A) = E_f(A) = \int_0^1 \frac{a_1(\gamma) + a_2(\gamma)}{2} f(\gamma) d\gamma,$$

which is the f -weighted possibilistic expected value of A introduced in [4].

Let us denote the projection functions on \mathbb{R}^2 by π_x and π_y , that is,

$$\pi_x(u, v) = u,$$

and

$$\pi_y(u, v) = v,$$

for $u, v \in \mathbb{R}$.

The following theorems show two important properties of the central value operator [5].

Theorem 3.1. *If $A, B \in \mathcal{F}$ are non-interactive and $g = \pi_x + \pi_y$ is the addition operator on \mathbb{R}^2 then*

$$\mathcal{C}_{[A \times B]^\gamma}(\pi_x + \pi_y) = \mathcal{C}_{[A]^\gamma}(\text{id}) + \mathcal{C}_{[B]^\gamma}(\text{id}) = \mathcal{C}([A]^\gamma) + \mathcal{C}([B]^\gamma),$$

for all $\gamma \in [0, 1]$.

Theorem 3.2. *If $A, B \in \mathcal{F}$ are non-interactive and $p = \pi_x \pi_y$ is the multiplication operator on \mathbb{R}^2 then*

$$\mathcal{C}_{[A \times B]^\gamma}(\pi_x \pi_y) = \mathcal{C}_{[A]^\gamma}(\text{id}) \cdot \mathcal{C}_{[B]^\gamma}(\text{id}) = \mathcal{C}([A]^\gamma) \cdot \mathcal{C}([B]^\gamma),$$

for all $\gamma \in [0, 1]$.

Definition 3.2. [5] *Let C be a joint possibility distribution with marginal possibility distributions $A, B \in \mathcal{F}$, and let $\gamma \in [0, 1]$. The measure of interactivity between the γ -level sets of A and B is defined by*

$$\mathcal{R}_{[C]^\gamma}(\pi_x, \pi_y) = \mathcal{C}_{[C]^\gamma}((\pi_x - \mathcal{C}_{[C]^\gamma}(\pi_x))(\pi_y - \mathcal{C}_{[C]^\gamma}(\pi_y))).$$

Using the definition of central value we have

$$\mathcal{R}_{[C]^\gamma}(\pi_x, \pi_y) = \mathcal{C}_{[C]^\gamma}(\pi_x \pi_y) - \mathcal{C}_{[C]^\gamma}(\pi_x) \cdot \mathcal{C}_{[C]^\gamma}(\pi_y)$$

for all $\gamma \in [0, 1]$.

Definition 3.3. [5] Let C be a joint possibility distribution in \mathbb{R}^2 , and let $A, B \in \mathcal{F}$ be its marginal possibility distributions. The covariance of A and B with respect to a weighting function f (and with respect to their joint possibility distribution C) is defined by

$$\begin{aligned} \text{Cov}_f(A, B) &= \int_0^1 \mathcal{R}_{[C]^\gamma}(\pi_x, \pi_y) f(\gamma) d\gamma \\ &= \int_0^1 [\mathcal{C}_{[C]^\gamma}(\pi_x \pi_y) - \mathcal{C}_{[C]^\gamma}(\pi_x) \cdot \mathcal{C}_{[C]^\gamma}(\pi_y)] f(\gamma) d\gamma. \end{aligned}$$

In [5] we proved that if $A, B \in \mathcal{F}$ are non-interactive then $\text{Cov}_f(A, B) = 0$. Zero correlation does not always imply non-interactivity. Let $A, B \in \mathcal{F}$ be fuzzy numbers, let C be their joint possibility distribution, and let $\gamma \in [0, 1]$. Suppose that $[C]^\gamma$ is symmetrical, i.e. there exists $a \in \mathbb{R}$ such that

$$C(x, y) = C(2a - x, y),$$

for all $x, y \in [C]^\gamma$ (hence, line defined by $\{(a, t) | t \in \mathbb{R}\}$ is the axis of symmetry of $[C]^\gamma$). It can be shown [3] that in this case the interactivity relation of $[A]^\gamma$ and $[B]^\gamma$ vanishes, i.e.

$$\mathcal{R}_{[C]^\gamma}(\pi_x, \pi_y) = 0,$$

(see Fig 2).

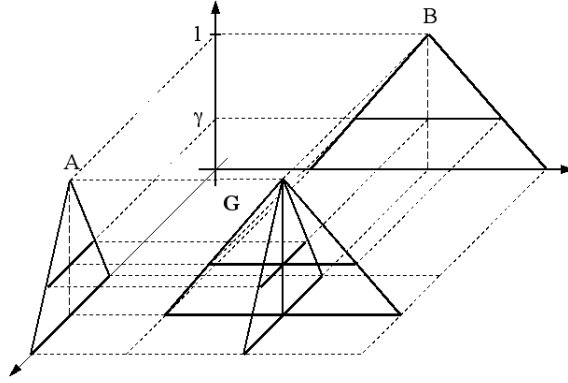

Figure 2: The case of $\rho_f(A, B) = 0$ for interactive fuzzy numbers.

In many papers authors consider joint possibility distributions that are derived from given marginal distributions by aggregating their membership values. Namely, let $A, B \in \mathcal{F}$. We will say that their joint possibility distribution C is *directly defined* from its marginal distributions if

$$C(x, y) = T(A(x), B(y)), \quad x, y \in \mathbb{R},$$

where $T: [0, 1] \times [0, 1] \rightarrow [0, 1]$ is a function satisfying the properties

$$\max_y T(A(x), B(y)) = A(x), \quad \forall x \in \mathbb{R},$$

and

$$\max_x T(A(x), B(y)) = B(y), \forall y \in \mathbb{R},$$

for example a triangular norm.

Remark 3.1. *In this case the joint distribution depends barely on the membership values of its marginal distributions.*

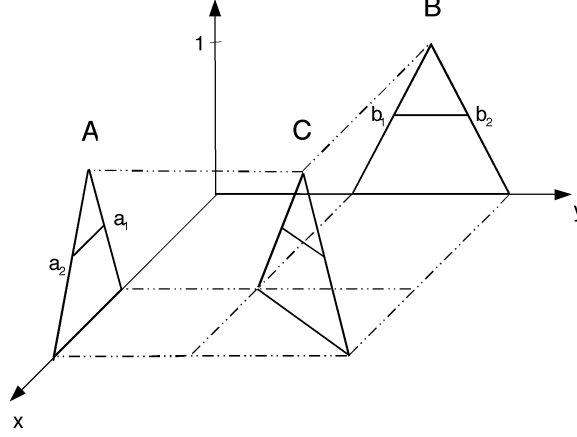

Figure 3: The case of $\rho_f(A, B) = 1$.

In [3] we have shown that in this case the covariance (and, consequently, the correlation) between its marginal distributions will be zero whenever at least one of its marginal distributions is symmetrical.

Theorem 3.3. [3] *Let $A, B \in \mathcal{F}$ and let their joint possibility distribution C be directly defined from its marginal distributions. If A is a symmetrical fuzzy number then*

$$\text{Cov}_f(A, B) = 0,$$

for any fuzzy number B and weighting function f .

Let us denote $\mathcal{R}_{[A]^\gamma}(\text{id}, \text{id})$ the average value of function

$$g(x) = (x - \mathcal{C}([A]^\gamma))^2,$$

on the γ -level set of an individual fuzzy number A . That is,

$$\mathcal{R}_{[A]^\gamma}(\text{id}, \text{id}) = \frac{1}{\int_{[A]^\gamma} dx} \int_{[A]^\gamma} x^2 dx - \left(\frac{1}{\int_{[A]^\gamma} dx} \int_{[A]^\gamma} x dx \right)^2.$$

Definition 3.4. *The variance of A is defined as the expected value of function*

$$g(x) = (x - \mathcal{C}([A]^\gamma))^2,$$

on A . That is,

$$\text{Var}_f(A) = E_f(g; A) = \int_0^1 \mathcal{R}_{[A]^\gamma}(\text{id}, \text{id}) f(\gamma) d\gamma.$$

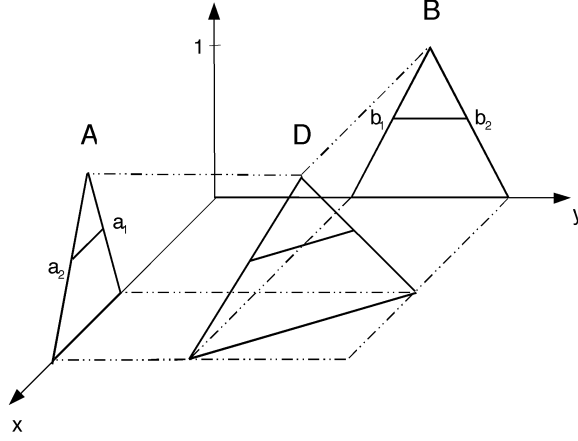

Figure 4: The case of $\rho_f(A, B) = -1$.

From the equality,

$$\mathcal{R}_{[A]^\gamma}(\text{id}, \text{id}) = \frac{(a_2(\gamma) - a_1(\gamma))^2}{12},$$

we get,

$$\text{Var}_f(A) = \int_0^1 \frac{(a_2(\gamma) - a_1(\gamma))^2}{12} f(\gamma) d\gamma.$$

In [5] we proved that the 'principle of central values' leads us to the same relationships in possibilistic environment as in probabilistic one. It is why we can claim that the principle of 'central values' should play an important role in defining possibilistic dependencies.

Theorem 3.4. [5] Let C be a joint possibility distribution in \mathbb{R}^2 , and let $\lambda, \mu \in \mathbb{R}$. Then

$$\begin{aligned} \mathcal{R}_{[C]^\gamma}(\lambda\pi_x + \mu\pi_y, \lambda\pi_x + \mu\pi_y) = \\ \lambda^2 \mathcal{R}_{[C]^\gamma}(\pi_x, \pi_x) + \mu^2 \mathcal{R}_{[C]^\gamma}(\pi_y, \pi_y) + 2\lambda\mu \mathcal{R}_{[C]^\gamma}(\pi_x, \pi_y). \end{aligned}$$

Furthermore, in [2] we have shown the following theorem.

Theorem 3.5. Let $A, B \in \mathcal{F}$ be fuzzy numbers (with $\text{Var}_f(A) \neq 0$ and $\text{Var}_f(B) \neq 0$) with joint possibility distribution C . Then, the correlation coefficient between A and B , defined by

$$\rho_f(A, B) = \frac{\text{Cov}_f(A, B)}{\sqrt{\text{Var}_f(A)\text{Var}_f(B)}}.$$

satisfies the property

$$-1 \leq \rho_f(A, B) \leq 1.$$

for any weighting function f .

Let us consider three interesting cases. In [4] we proved that if A and B are independent, that is, their joint possibility distribution is $A \times B$ then $\rho_f(A, B) = 0$. Consider now the case depicted in Fig. 3. It can be shown [2] that in this case $\rho_f(A, B) = 1$. Consider now the case depicted in Fig. 4. It can be shown [2] that in this case $\rho_f(A, B) = -1$. Consider now the case depicted in Fig. 5. It can be shown that in this case $\rho_f(A, B) = 1/3$.

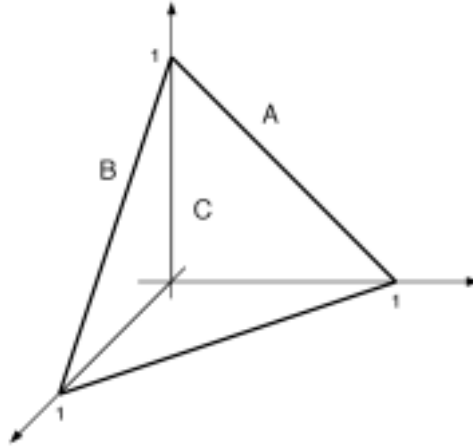

Figure 5: The case of $\rho_f(A, B) = 1/3$.

4 Summary

We have illustrated some important features of possibilistic mean value, covariance, variance and correlation by several examples. We have shown that zero correlation does not always imply non-interactivity. We have also shown the limitations of direct definitions of joint possibility distributions from individual fuzzy numbers, for example, when one simply aggregates the membership values of two fuzzy numbers by a triangular norm

References

- [1] C. Carlsson, R. Fullér, On possibilistic mean value and variance of fuzzy numbers, *Fuzzy Sets and Systems*, 122(2001) 315-326.
- [2] C. Carlsson, R. Fullér and P. Majlender, On possibilistic correlation, *Fuzzy Sets and Systems*, (submitted).
- [3] C. Carlsson, R. Fullér and P. Majlender, A normative view on possibility distributions, in: Masoud Nikraves, Lotfi A. Zadeh and Victor Korotkikh eds., *Fuzzy Partial Differential Equations and Relational Equations: Reservoir Characterization and Modeling*, Springer Verlag (to appear).
- [4] R. Fullér and P. Majlender, On weighted possibilistic mean and variance of fuzzy numbers, *Fuzzy Sets and Systems*, 136(2003) 363-374.
- [5] R. Fullér and P. Majlender, On interactive fuzzy numbers, *Fuzzy Sets and Systems* (to appear).
- [6] L. A. Zadeh, Fuzzy Sets, *Information and Control*, 8(1965) 338-353.
- [7] L. A. Zadeh, Fuzzy sets as a basis for a theory of possibility, *Fuzzy Sets and Systems*, 1(1978) 3-28.